

Behind the Windows

giellesse

giellesse

Behind the Windows

Uno sguardo che attraversa. Un'apertura che invita a scoprire nuovi scenari abitativi. La nuova collezione Giellesse si racconta attraverso ambienti sospesi tra luce e materia, tra giorno e notte. Spazi essenziali, definiti da volumi rigorosi e superfici tattili, in una palette neutra di sabbia, pietra e luce. Ogni ambiente è un frammento di architettura contemporanea, dove il design si fa esperienza silenziosa, misurata, profonda. Un invito a vivere l'interiorità dello spazio con uno sguardo nuovo.

A gaze that sees through. An opening that invites the discovery of new living scenarios. The new Giellesse collection unfolds through spaces suspended between light and matter, between day and night. Essential spaces, defined by strict volumes and tactile surfaces, in a neutral palette of sand, stone, and light. Each setting is a fragment of contemporary architecture, where design becomes a silent, measured, and profound experience. An invitation to experience the interiority of space with a fresh perspective.

Behind the Windows

Window #01

11

FLEXUS SYSTEM
BEND TABLE
CLARICE CHAIR
ARCHIWALL PANELING SYSTEM

Window #02

29

FRAME SYSTEM
MANHATTAN ARMCHAIR
JERRY COFFEE TABLE

Window #03

41

FRAME SYSTEM
DOWNTOWN SOFA
TUDOR COFFEE TABLE
INFINITY COFFEE TABLE
CLUB ARMCHAIR

Window #04

47

FLEXUS SYSTEM
TUDOR COFFEE TABLE
MANHATTAN ARMCHAIR
JERRY COFFEE TABLE

Window #05

59

FRAME SYSTEM
FLEXUS SYSTEM
CLUB ARMCHAIR
INFINITY COFFEE TABLE
DOWNTOWN SOFA

Window #6

71

FLEXUS SYSTEM (CAVE À VIN)

Window #07

79

POCKET WARDROBE
ARCHIWALL PANELING & DOORS SYSTEM
KYOTO BED
ALLROUND CHEST OF DRAWERS AND NIGHT TABLES
SOFT CIRCLE POUF

Window #08

91

SHEER WARDROBE
FRAME DESK
SOFT CIRCLE POUF

Window #09

99

POCKET WARDROBE
ARCHIWALL PANELING & DOORS SYSTEM
ALLROUND CHEST OF DRAWERS AND NIGHT TABLES

Window #10

107

COVER WARDROBE
IROHA WARDROBE
CABIN WALK-IN CLOSET SYSTEM
ISLAND SEAT CHEST OF DRAWERS
FRAME DESK
JAM MIRROR







Window #01

Day System

FLEXUS

ARCHIWALL PANELING SYSTEM

Complements

BEND TABLE

CLARICE CHAIR



















Window #02

Day System

FRAME

Complements

MANHATTAN ARMCHAIR

JERRY COFFEE TABLE













Window #03

Day System

FRAME

Complements

DOWNTOWN SOFA

TUDOR COFFEE TABLE

INFINITY COFFEE TABLE

CLUB ARMCHAIR







Window #04

Day System

FLEXUS

Complements

TUDOR COFFEE TABLE

MANHATTAN ARMCHAIR

JERRY COFFEE TABLE













Window #05

Day System

FRAME

FLEXUS

Complements

CLUB ARMCHAIR

INFINITY COFFEE TABLE

DOWNTOWN SOFA













Window #06

Day System

FLEXUS (CAVE À VIN)









Window #07

Night System

POCKET WARDROBE

ARCHIWALL PANELING & DOORS

Complements

KYOTO BED

ALLROUND CHEST OF DRAWERS AND NIGHT TABLES

SOFT CIRCLE POUF







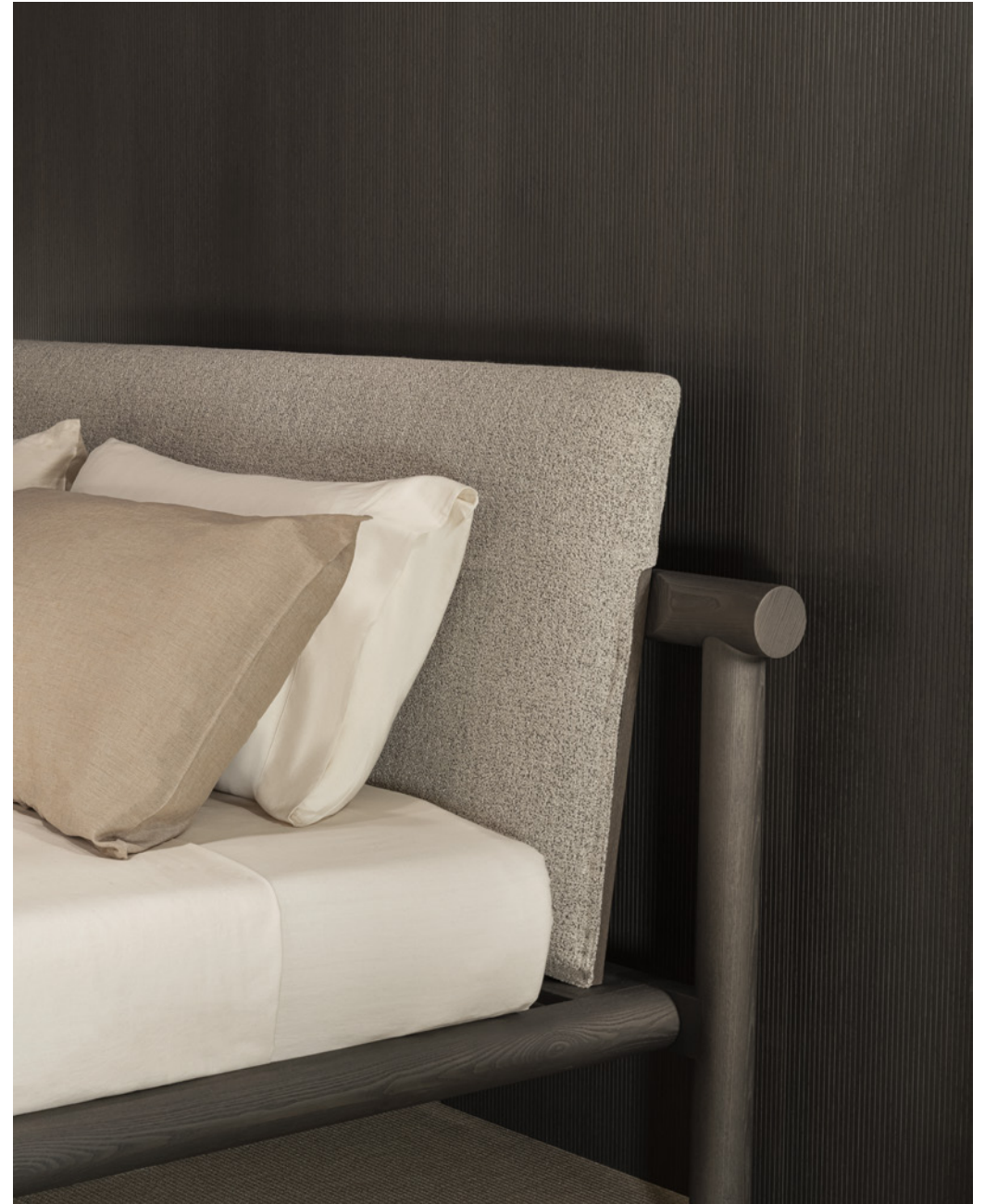





Window #08

Night System

SHEER WARDROBE

Complements

FRAME DESK

SOFT CIRCLE POUF









Window #09

Night System

POCKET WARDROBE

ARCHIWALL PANELING & DOORS

Complements

ALLROUND CHEST OF DRAWERS AND NIGHT TABLES



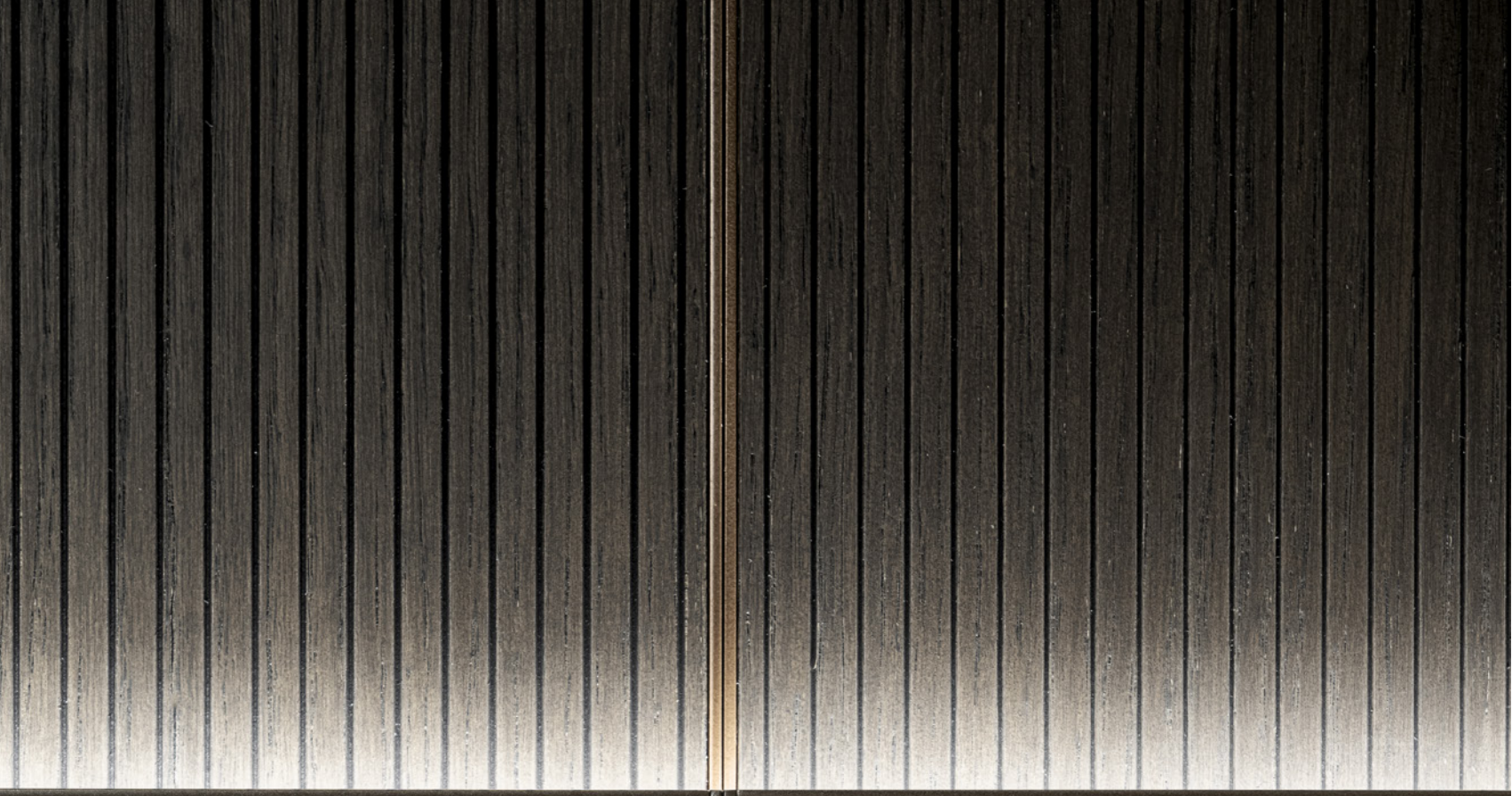





Window #10

Night System

COVER WARDROBE

IROHA WARDROBE

CABIN WALK-IN CLOSET

Complements

ISLAND SEAT CHEST OF DRAWERS

FRAME DESK

JAM MIRROR





















giellese

Specifications & Finishes

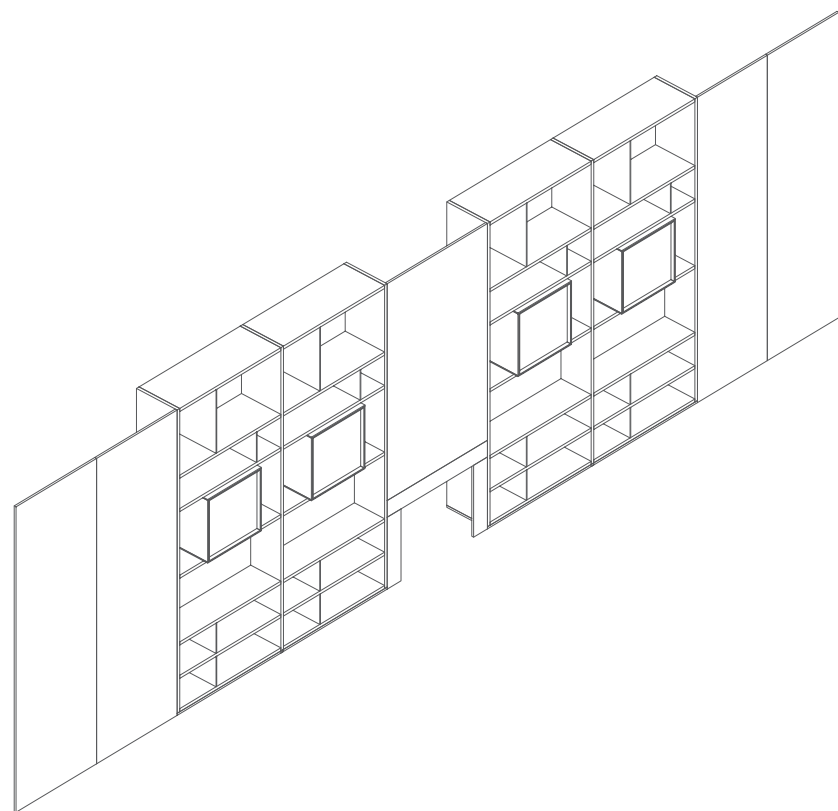

Il sistema modulare Flexus ridefinisce lo spazio domestico grazie alla sua costante evoluzione. Con una filosofia di design che unisce funzionalità ed estetica, Flexus crea ambienti dinamici e personalizzati, ispirati alle architetture urbane. Ogni elemento è progettato per integrarsi perfettamente nello stile di vita contemporaneo, offrendo soluzioni innovative e flessibili per le aree living. Oggi Flexus si arricchisce della progettualità del nuovo sistema boiserie Archiwall, che aggiunge una nuova dimensione di design e di possibilità creative. Insieme, Flexus e Archiwall creano uno spazio domestico dove l'estetica e la libertà di espressione si incontrano, offrendo infinite possibilità di configurazione.

The Flexus modular system redefines the domestic space thanks to its continuous evolution. With a design philosophy that combines functionality and aesthetics, Flexus creates dynamic, personalized environments inspired by urban architecture. Every element is designed to integrate seamlessly into contemporary lifestyles, offering innovative and flexible solutions for living areas. Today, Flexus is further enriched by the design potential of the new Archiwall boiserie system, which adds a new dimension of design and creative possibilities. Together, Flexus and Archiwall create a home space where aesthetics and freedom of expression meet, offering endless configuration possibilities.

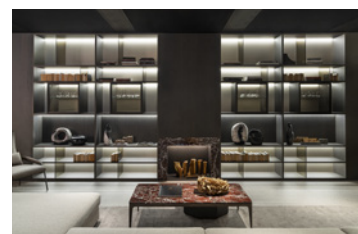
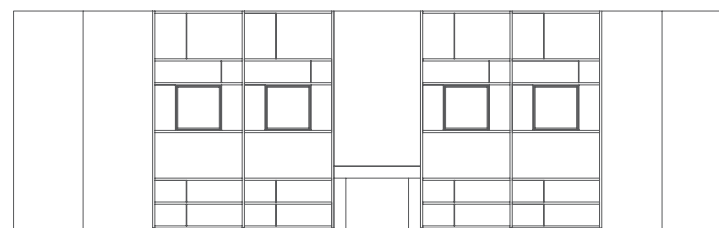

Dimensioni / Dimensions
 W. 920 cm (boiserie include - wall panelling included)
 H. 293 cm
 D. 44 cm

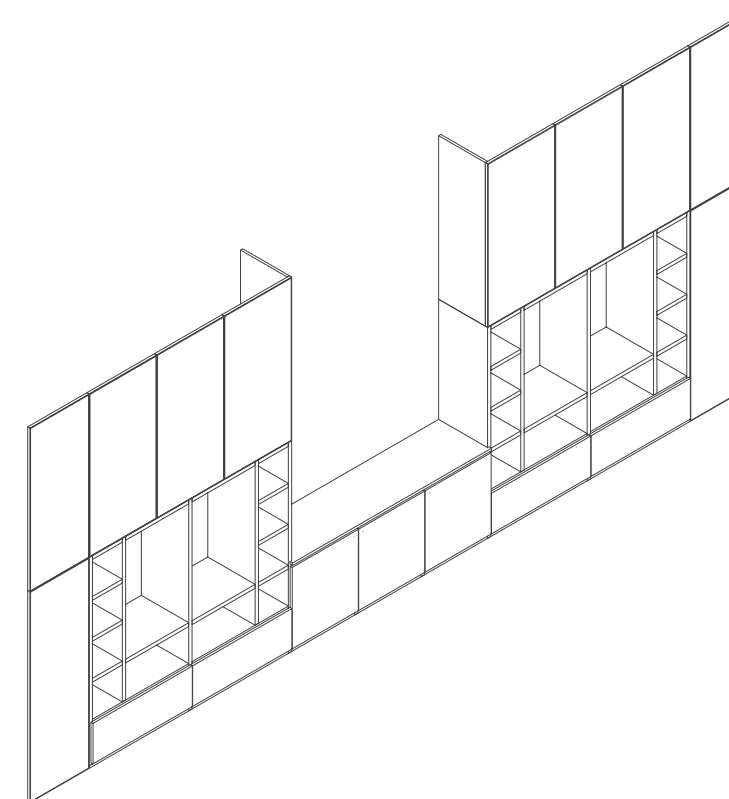

La collezione Flexus si distingue per le sue soluzioni di design innovative, che includono schienali in tessuto o fresati e boiserie Archiwall con finiture lisce o bordate in alluminio. Questi elementi, disponibili in una vasta gamma di texture, offrono infinite possibilità di personalizzazione e di espressione creativa. Gli schienali in tessuto apportano comfort ed eleganza, mentre i pannelli fresati e le boiserie introducono modernità e sofisticatezza, creando un perfetto equilibrio tra estetica e funzionalità. Il piano superiore della parte centrale della composizione è caratterizzato dall'utilizzo del marmo, che aggiunge un tocco di lusso e raffinatezza al prodotto, valorizzandolo ulteriormente.

The Flexus collection stands out for its innovative design solutions, which include fabric or grooved back panels and Archiwall boiserie with smooth finishes or aluminum-edged detailing. These elements, available in a wide range of textures, offer endless possibilities for customization and creative expression. The fabric back panels bring comfort and elegance, while the grooved panels and boiserie introduce modernity and sophistication, creating a perfect balance between aesthetics and functionality. The upper surface of the central part of the composition features the use of marble, adding a touch of luxury and refinement that further enhances the product.

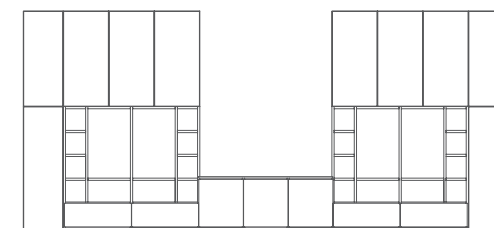

Dimensioni / Dimensions
 W. 650 cm
 H. 293 cm
 D. 44 cm



Flexus System

pag. 72

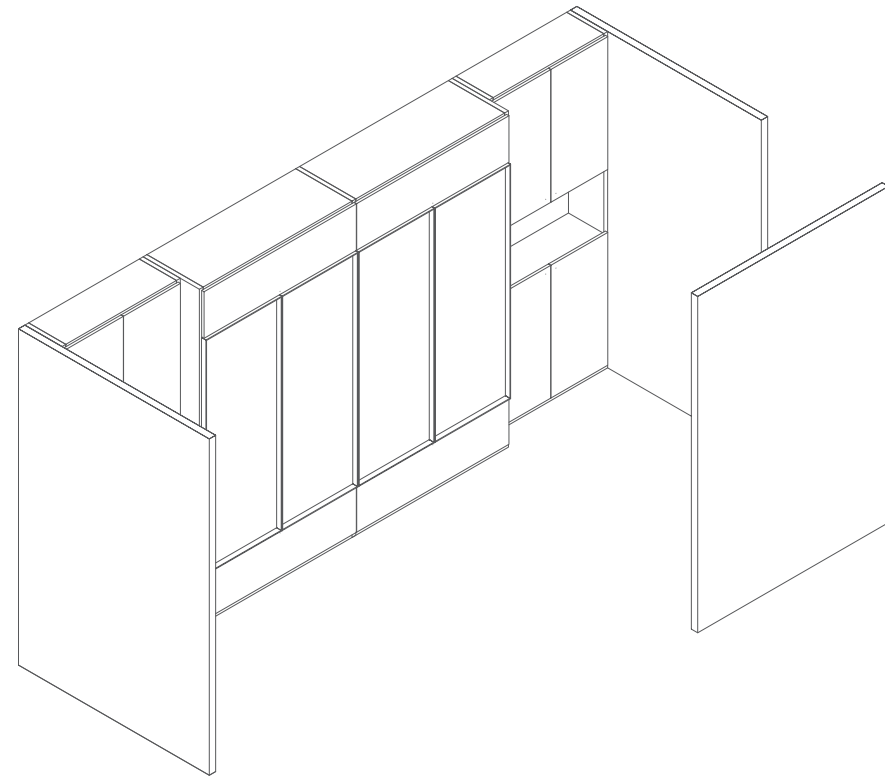

Il programma Flexus interpreta, in questa configurazione, un'elegante e funzionale cantina dei vini. Concepito come un'unità autonoma e versatile, si integra armoniosamente nella proposta del programma, offrendo una soluzione di design moderna e funzionale per gli spazi living. Gli schienali fresati caratterizzano elegantemente la presentazione, arricchendola in modo personale e contribuendo a rendere il sistema un oggetto culto insostituibile in un living contemporaneo. Completano lo schema compositivo i ripiani porta bottiglie inclinati e i vassoi porta bicchieri. La composizione vive inoltre di una propria dimensione architettonica grazie alle boiserie Archiwall a forte spessore (5 cm) con fissaggio pavimento/soffitto.

The Flexus system, in this configuration, is interpreted as an elegant and functional wine cellar. Conceived as an independent and versatile unit, it integrates harmoniously into the overall program, offering a modern and functional design solution for living spaces. The grooved back panels elegantly characterize the presentation, enriching it with a personal touch and helping to make the system an irreplaceable cult object in contemporary living rooms. The composition is completed by the inclined bottle shelves and glass holder trays. The arrangement also boasts its own architectural dimension thanks to the thick (5 cm) Archiwall boiserie with floor-to-ceiling mounting.

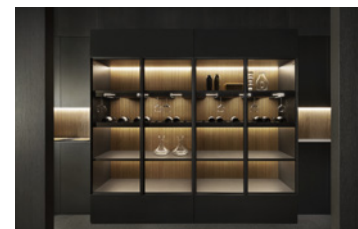
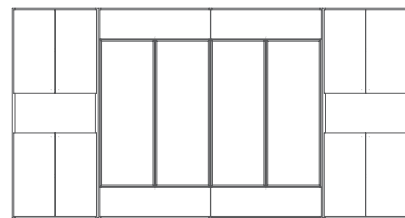

Dimensioni / Dimensions
W. 429 cm
H. 229 cm
D. 29/44 cm

Frame System

pag. 60

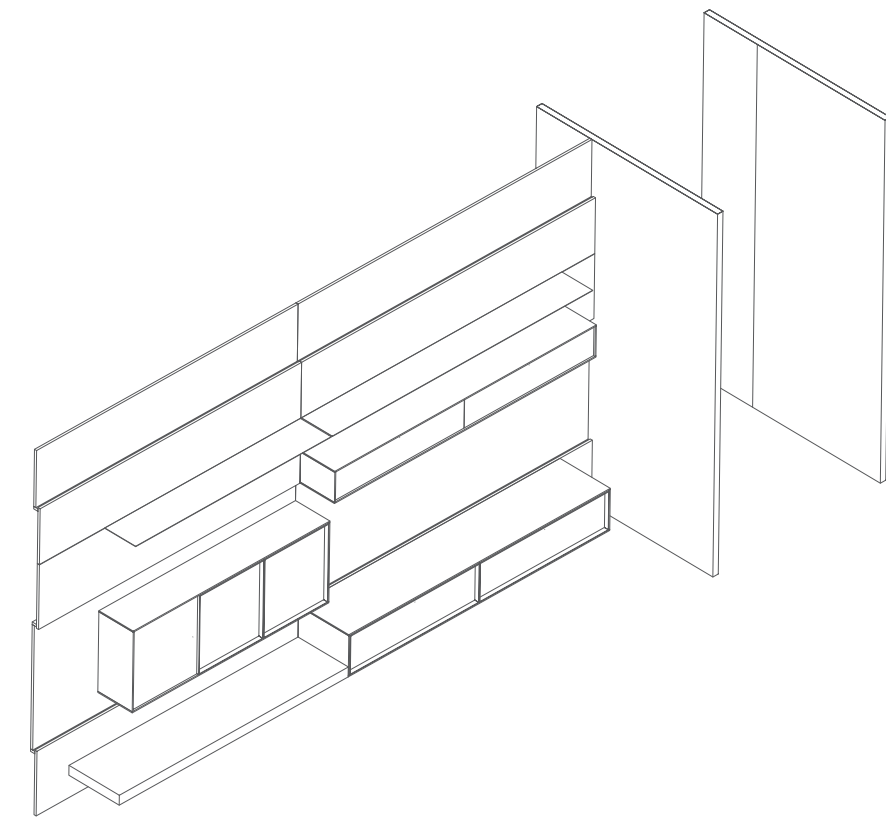

Frame, il sistema living per la casa contemporanea, si rinnova per rispondere alle esigenze di un nuovo stile abitativo. La collezione si evolve per offrire un'esperienza più integrata e flessibile, dove libri, oggetti decorativi e sistemi multimediali coesistono in armonia, creando un ambiente domestico che è al tempo stesso funzionale, estetico e altamente personalizzabile. I pannelli boiserie rivestono le pareti elevando la qualità dell'architettura grazie a materiali pregiati come il laccato e l'essenza, presentata in versione liscia o fresata. Grazie al sistema di fissaggio delle pannellature e dei loro cambi di profondità è possibile creare tagli luminosi che diffondono la luce nell'ambiente circostante. La proposta compositiva si arricchisce inoltre della presenza delle pannellature boiserie Archiwall, utilizzate in questo caso, per creare un hallway divisorio di qualità superiore.

Frame, the living system for contemporary homes, has been renewed to meet the needs of a new style of living. The collection evolves to offer a more integrated and flexible experience, where books, decorative objects, and multimedia systems coexist in harmony, creating a home environment that is functional, aesthetic, and highly customizable at the same time. The boiserie panels clad the walls, enhancing the architectural quality through fine materials such as lacquer and wood veneer, available in smooth or grooved versions. Thanks to the fastening system of the panels and their varying depths, it is possible to create luminous slits that diffuse light into the surrounding space. The composition is further enriched by the presence of Archiwall boiserie panels, used in this case to create a superior-quality partition hallway.



Dimensioni / Dimensions
W. 482 cm
H. 293 cm
D. 53,8 cm

Frame System

pag. 30

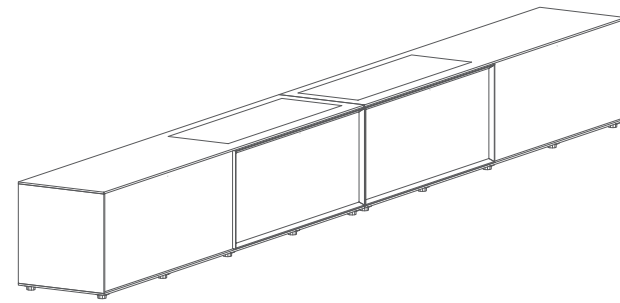

Frame si arricchisce oggi con l'inedito top superiore con inserti in vetro, che aggiunge un tocco di luce e trasparenza agli elementi della collezione. Gli inserti in vetro creano un effetto visivo unico e sofisticato, valorizzando gli oggetti in essi inseriti e arricchendo l'ambiente domestico con un elemento di design innovativo e di grande effetto.

Frame is now enhanced by the new top with glass inserts, adding a touch of light and transparency to the elements of the collection. The glass inserts create a unique and sophisticated visual effect, highlighting the objects placed within them and enriching the home environment with an innovative and striking design element.

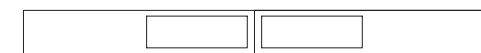

Dimensioni / Dimensions
 W. 484 cm
 H. 52,5 cm
 D. 43,3 cm

Archiwall System

pag. 16

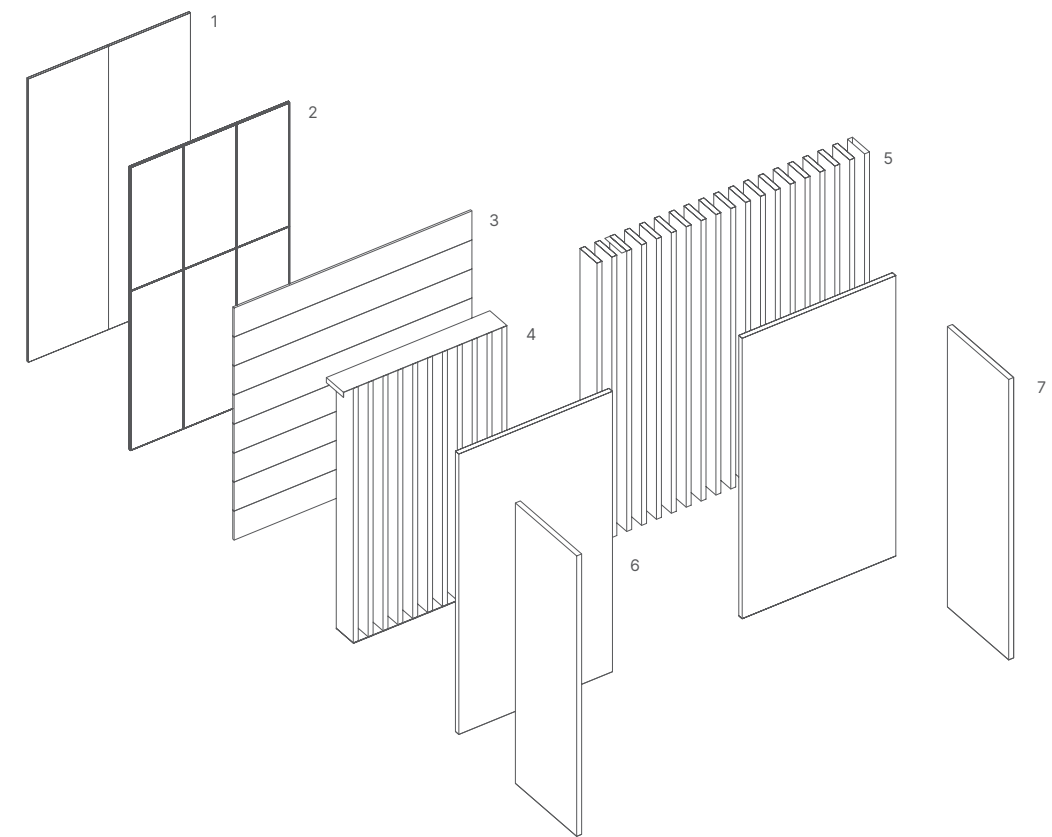

Archiwall è il sistema di rivestimento murale e di divisione degli spazi che unisce design e flessibilità. Con Archiwall, puoi creare spazi unici e personalizzati, grazie alla sua vasta gamma di moduli e configurazioni. Il suo design innovativo e la sua struttura modulare ti permettono di realizzare pareti che non sono solo funzionali, ma anche veri e propri elementi d'arredo. Archiwall è pensato per soddisfare le esigenze di ogni spazio, dalle abitazioni private agli spazi commerciali. La sua flessibilità ti consente di creare configurazioni personalizzate, adattandosi alle tue esigenze specifiche. Le caratteristiche architettoniche di Archiwall sono state studiate per garantire una perfetta integrazione con ogni ambiente.

Archiwall is the wall covering and space-partitioning system that combines design and flexibility. With Archiwall, you can create unique and personalized spaces thanks to its wide range of modules and configurations. Its innovative design and modular structure allow you to create walls that are not only functional but also true furnishing elements. Archiwall is designed to meet the needs of any space, from private homes to commercial environments. Its flexibility allows you to create customized configurations, adapting perfectly to your specific requirements. The architectural features of Archiwall have been developed to ensure seamless integration into any setting.

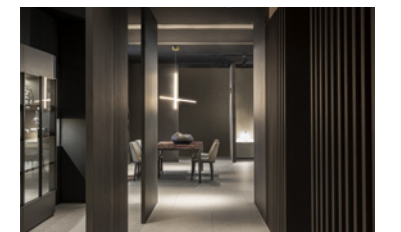
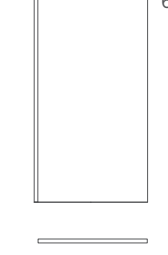
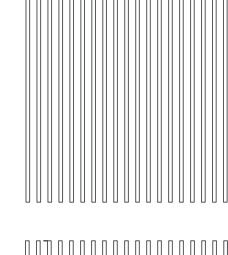
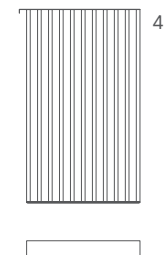
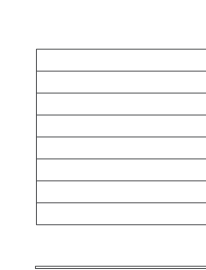
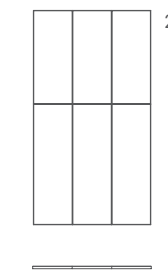
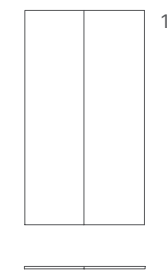

Sheer Wardrobe

pag. 92

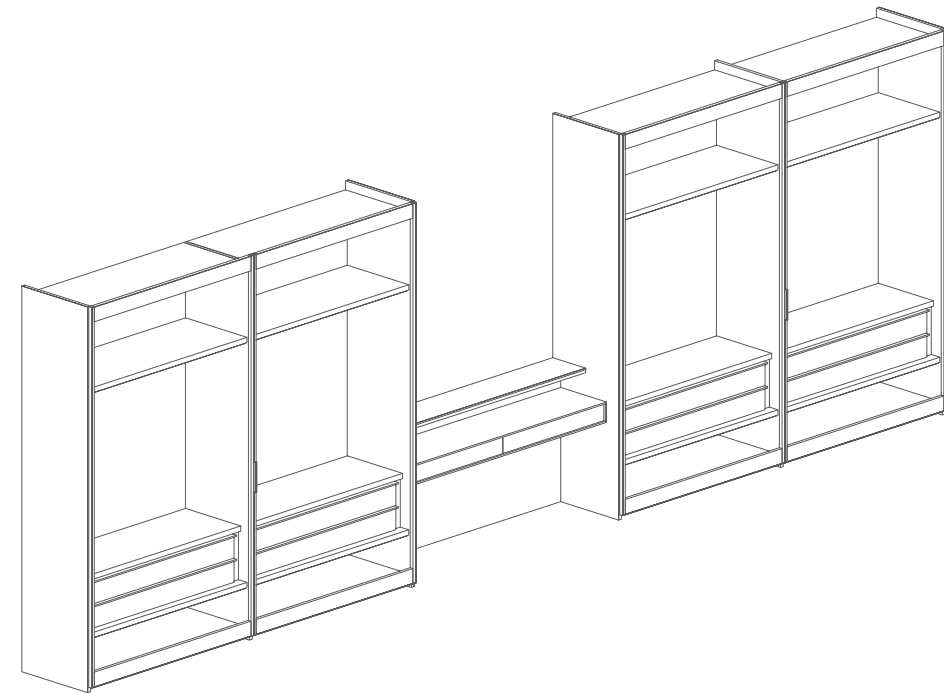

L'armadio Sheer incarna l'eleganza e la trasparenza, grazie alle ante cristallo Stopsol bronzo incorniciate dal telaio alluminio in finitura Metal Bronzo, l'apertura complanare crea un effetto di continuità e armonia nello spazio. La composizione è articolata in due moduli simmetrici, intervallati al centro dal desk della collezione Frame, abbinato alla mensola sottoilluminata, creando un perfetto equilibrio tra stile e funzionalità. Sheer illumina il tuo spazio con stile e raffinatezza.

The Sheer wardrobe embodies elegance and transparency, thanks to its Stopsol bronze glass doors framed by an aluminum structure in a Metal Bronze finish. The coplanar opening creates an effect of continuity and harmony within the space. The composition is arranged in two symmetrical modules, separated at the center by the Frame collection desk, paired with the underlit shelf, creating a perfect balance between style and functionality. Sheer lights up your space with style and refinement.

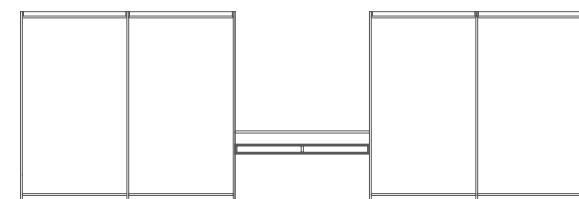

Dimensioni / Dimensions
W. 763 cm
H. 255 cm
D. 61,5 cm

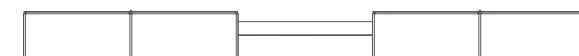

Pocket Wardrobe + Archiwall

pag. 80

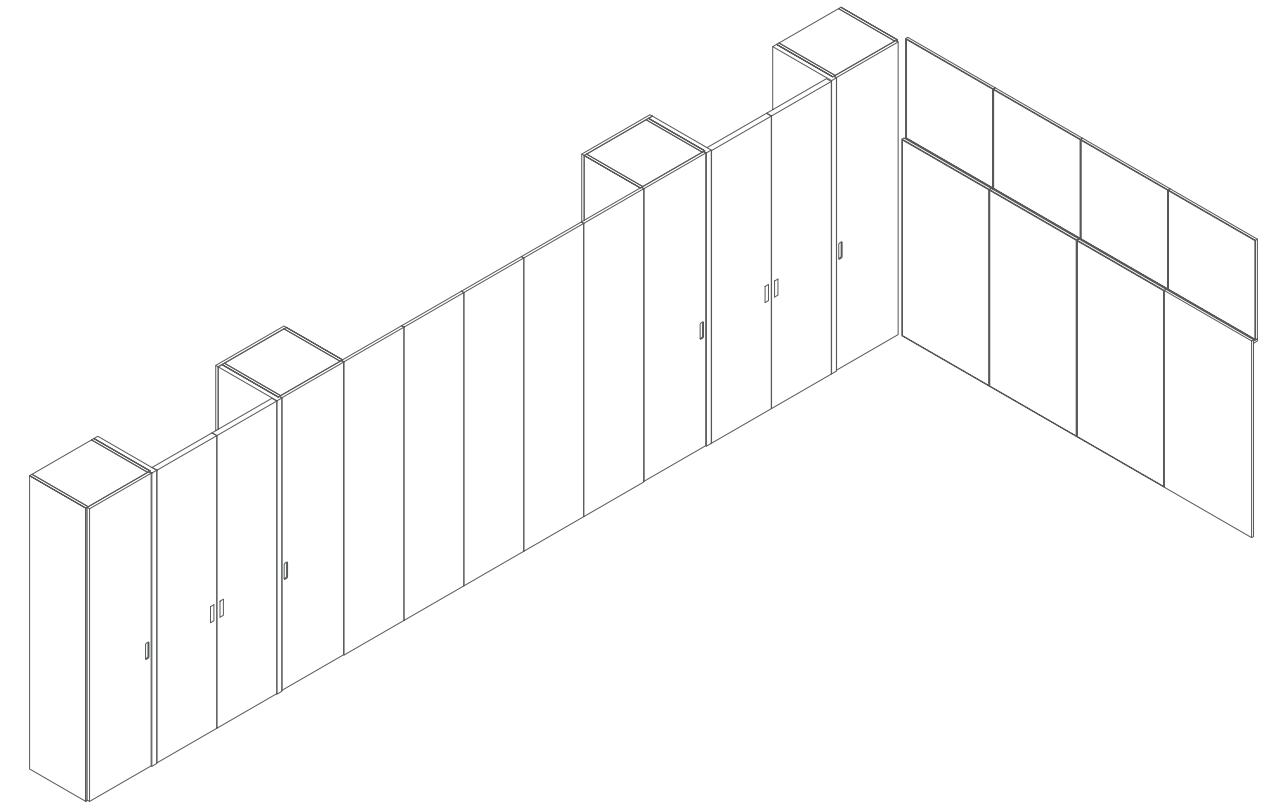

L'armadio Pocket è caratterizzato da ante battenti in finitura Rovere Honey e maniglie in alluminio Metal Bronzo lavorate con cura artigianale. In questa configurazione trova la sua massima espressione fondendosi con il sistema boiserie e porte Archiwall. I pannelli in legno fresato, rivestiti in tessuto, creano un'atmosfera di lusso e sofisticatezza, mentre la texture del legno e la morbidezza del velluto si incontrano con la precisione e la modernità dell'anta Pocket. Il risultato è un connubio perfetto di tradizione e innovazione, di calore e raffinatezza. Un ambiente che ti avvolge e ti fa sentire a casa, dove ogni dettaglio è stato pensato per creare un'esperienza unica e indimenticabile.

The Pocket wardrobe is distinguished by hinged doors in a Honey Oak finish and Metal Bronze aluminum handles, crafted with artisanal care. In this configuration, it finds its highest expression by blending seamlessly with the Archiwall boiserie and door system. The grooved wooden panels, upholstered in fabric, create an atmosphere of luxury and sophistication, where the texture of the wood and the softness of the velvet meet the precision and modernity of the Pocket door. The result is a perfect combination of tradition and innovation, of warmth and refinement. A space that embraces you and makes you feel at home, where every detail has been designed to create a unique and unforgettable experience.

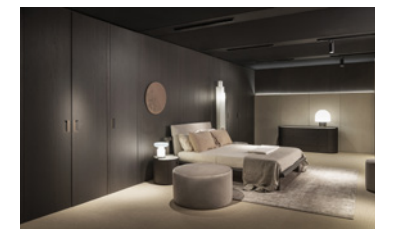
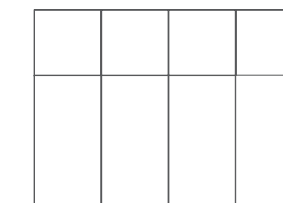
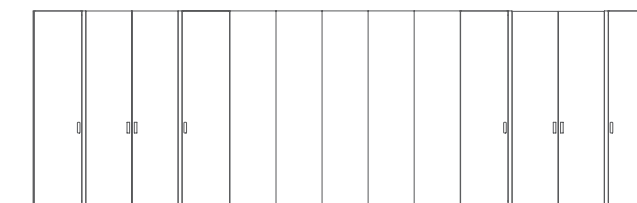

Dimensioni / Dimensions (Pocket Wardrobe)
W. 838 cm
H. 262,4 cm
D. 61 cm



Dimensioni / Dimensions (Archiwall wall paneling)
W. 360 cm
H. 262,4 cm
D. 6,5 cm

Cover Wardrobe + Iroha Wardrobe + Crystal Glass Wardrobe

pag. 117

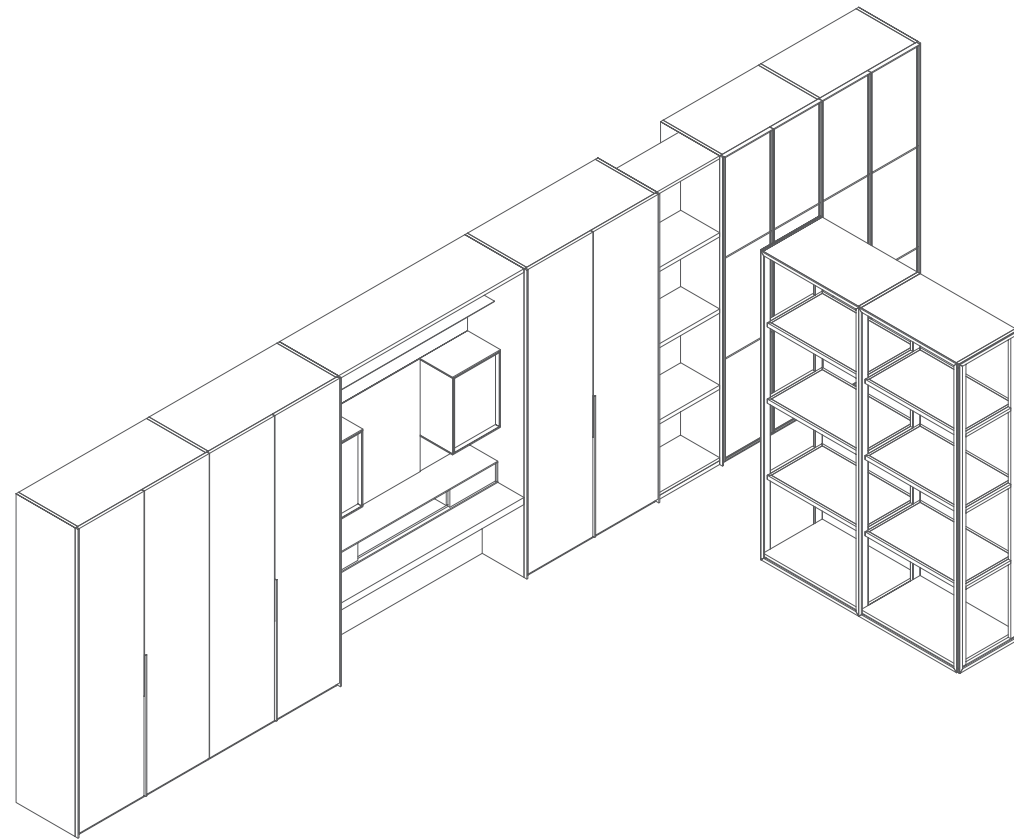

Un ambiente di lusso e raffinatezza, dove l'armadio Cover con ante rivestite in tessuto e bordate in alluminio, si abbina perfettamente al nuovo armadio Iroha con ante battenti di ispirazione orientale. Il design essenziale e moderno dell'armadio Cover si fonde armoniosamente con la purezza delle linee e la spiritualità dell'armadio Iroha e dell'elemento Crystal, creando un'atmosfera suggestiva e raffinata. Completa l'insieme il nuovo make-up desk della serie Frame, con preziosi contenitori portoggetti che aggiungono un tocco di eleganza e praticità allo spazio. Un ambiente che è il risultato di una sapiente unione di stile, funzionalità e raffinatezza, dove ogni dettaglio è studiato per creare un'esperienza unica.

A space of luxury and refinement, where the Cover wardrobe with fabric-covered doors edged in aluminum pairs perfectly with the new Iroha wardrobe, featuring hinged doors inspired by oriental design. The essential and modern design of the Cover wardrobe blends harmoniously with the purity of the lines and the spirituality of the Iroha wardrobe and the Crystal element, creating an evocative and sophisticated atmosphere. Completing the ensemble is the new make-up desk from the Frame series, with elegant storage compartments that add a touch of elegance and practicality to the space. A setting that is the result of a masterful combination of style, functionality, and refinement, where every detail is designed to create a unique experience.

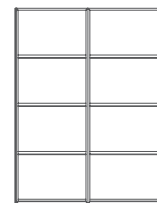
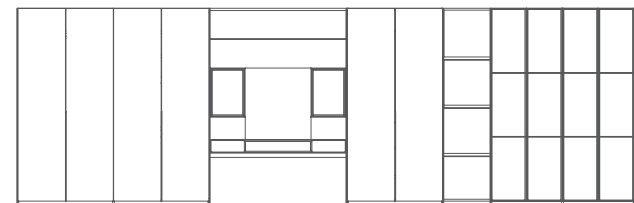

**Dimensioni / Dimensions
(Cover + Iroha + Frame desk)**
W. 827 cm
H. 262,4 cm
D. 61,5 cm

**Dimensioni / Dimensions
(Crystal Glass Wardrobe)**
W. 195,5 cm
H. 262,4 cm
D. 58 cm

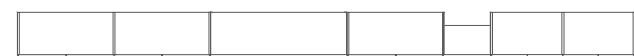

Cabin Walk-in closet + Island Seat chest of drawers

pag. 127

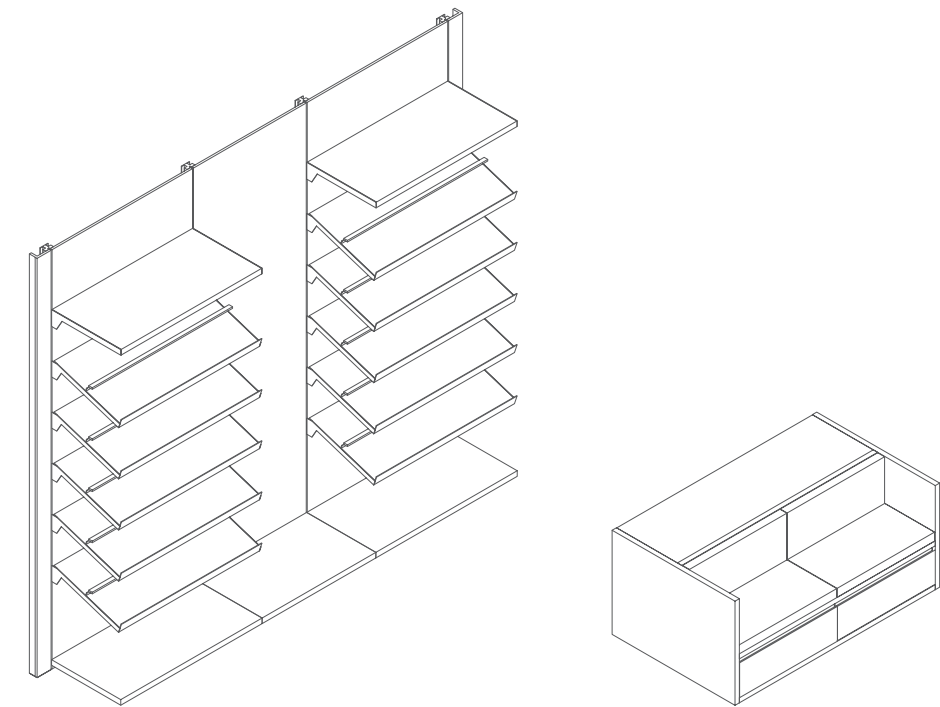

La cabina armadio Cabin è un perfetto equilibrio tra stile e funzionalità, grazie alla combinazione di boiserie e sistema a cremagliera. La sua struttura modulare è composta da pannelli a parete disponibili in diverse finiture e può essere accessoriata con ripiani e attrezzature per creare uno spazio unico e funzionale. Le opzioni di finitura sono numerose e variegata, dal classico nobilitato legno al laccato, fino alla nuova ed esclusiva variante in tessuto. Il sistema a cremagliera è personalizzabile, negli accessori, con finiture metalliche. Con Cabin, è possibile creare uno spazio di archiviazione personalizzato, dotato di contenitori e accessori come vassoi, cassetti, scarpriere, portapantaloni e portacamicie regolabili, per soddisfare ogni esigenza.

The Cabin walk-in wardrobe is a perfect balance between style and functionality, thanks to the combination of wall panelling and a rack system. Its modular structure is made up of wall panels available in various finishes and can be fitted with shelves and equipment to create a unique and functional space. The finishing options are numerous and varied, ranging from classic wood veneer to lacquered surfaces, all the way to the new and exclusive fabric variant. The rack system is customizable with accessories available in metallic finishes. With Cabin, it is possible to create a personalized storage space, equipped with containers and accessories such as trays, drawers, shoe racks, trouser racks, and adjustable shirt holders, to meet every need.

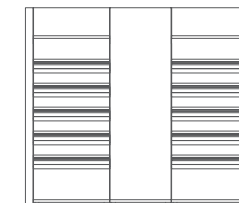

Dimensioni / Dimensions
W. 307,6 cm
H. 262,4 cm
D. 55,6 cm

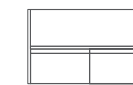

Laccato Opaco *Matt Lacquered*



Laccato Lucido *Glossy Lacquered*



Laccato Metal *Metal Lacquered*

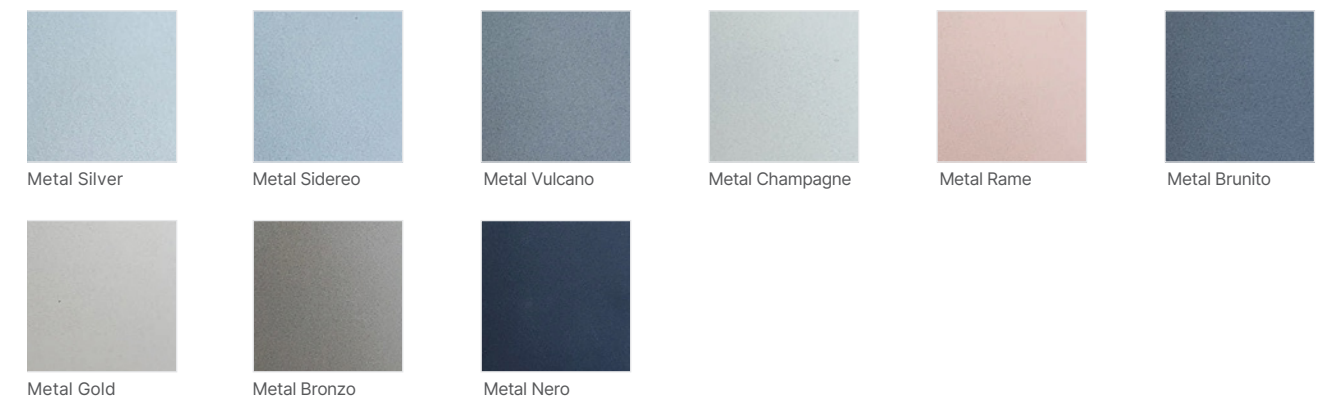

Essenza *Veneer*

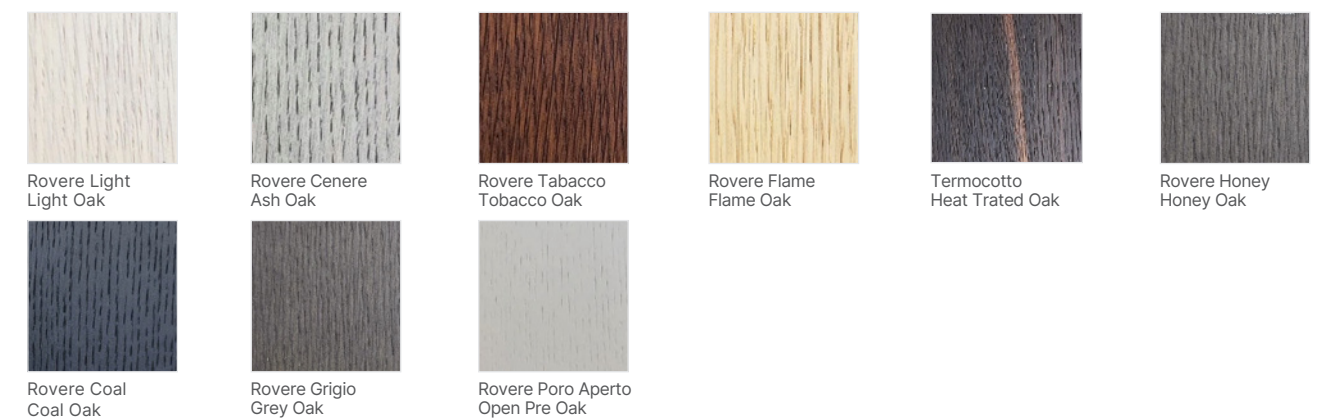

Fresato *Milled*



Finitura fresata disponibile in tutte le essenze, tinte e colorazioni laccate a campionario.
Milled finish available in all wood species, stains and lacquer colours from the sample collection.

Melaminico *Melamine*

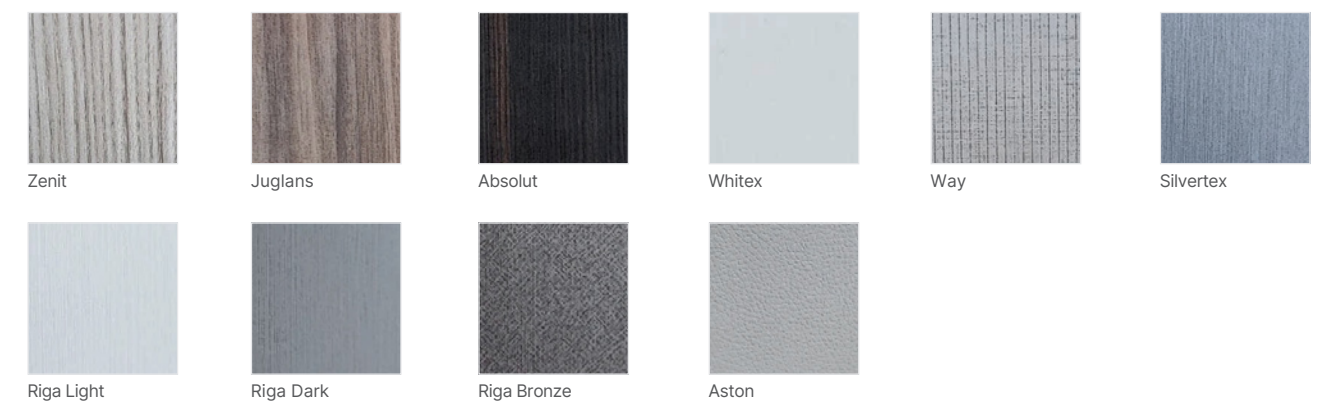

Marmo_Marble



Vetro Laccato Opaco_Matt Lacquered Glass



Vetro Laccato Lucido_Glossy Lacquered Glass



Vetro_Glass

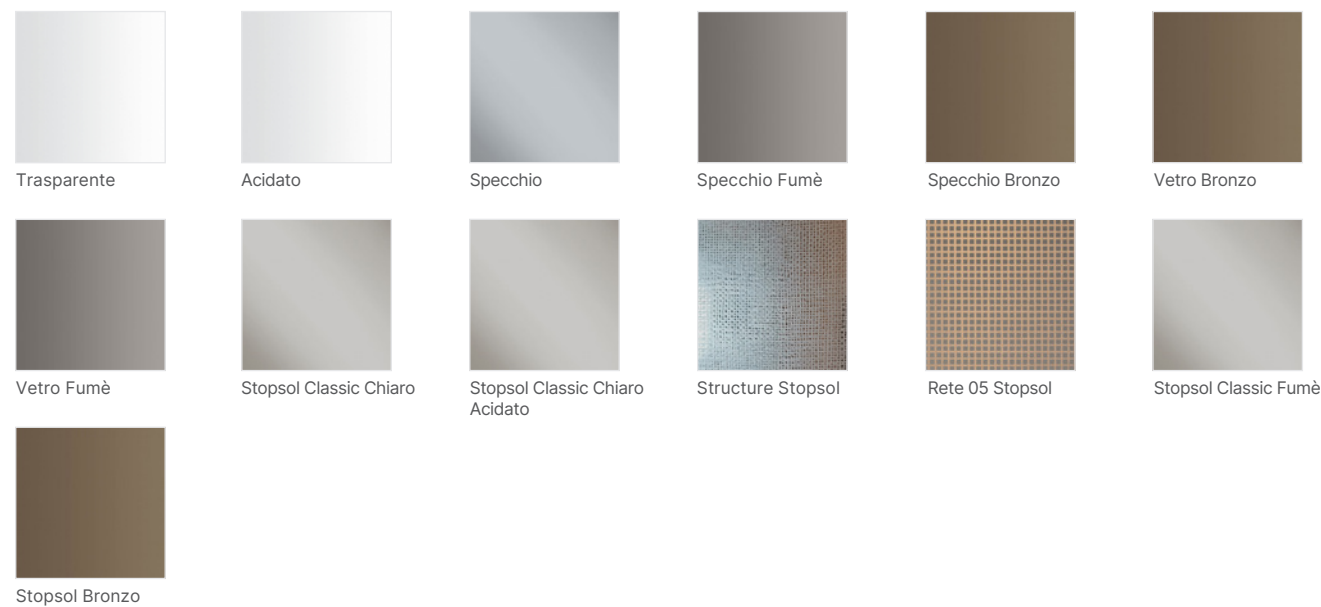

Cuoio_Hide



Pelle_Leather



Tessuti_Fabric

Il campionario tessuti è consultabile online all'indirizzo <https://www.giellesse.it/tessuti> oppure disponibile nel listino generale.
The fabric collection can be viewed online at <https://www.giellesse.it/tessuti> or consulted in the general price list.

Art Direction: Massimiliano Mornati
Concept & Graphic: Emiliano Besana
Photo: Lorenzo Pennati
Styling: Cristina Corbetta
Printing: Grafiche Boffi

Credits:
AeD Saini
Flanerie
Magazzino76
Myprops
Noleggiocose
Officina84
Sonia Armellin
StudioT
Zanetto

© Giellesse 2025
Tutti i diritti riservati.
Nessuna parte del presente catalogo
può essere riprodotta o diffusa
con un mezzo qualsiasi, fotocopie,
microfilm o altro, senza il permesso
del titolare del copyright.

All rights reserved.
No part of this catalogue
can be reproduced or spread
by any means, photocopying,
microfilm or others, without the copyright
holder's permission.

giellesse

Via Prealpi, 34
22044 Inverigo
Como, Italy

T +39 031 607090
giellesse@giellesse.it
www.giellesse.it

